

Features

HIGH CURRENT CARRY AND HIGH VOLTAGE

Inert gas filled arc chamber suitable for high voltage switching

COMPACT STRUCTURE, LOW NOISE

Small, low-profile design with low noise while carrying or switching loads

SAFE FOR EXPLOSIVE ENVIRONMENTS

No arc leakage due to a hermetically sealed design

HIGH RELIABILITY DESIGN

Hermetic sealing creates a stable environment for high voltage switching

NO SPECIFIC MOUNTING ARRANGEMENT

Mountable in any orientation without reduction of performance

VARIOUS APPLICATIONS

Battery disconnect, EV charging, energy storage systems, photovoltaics, power control, circuit protection and much more

Sealing Type: Epoxy/Resin

- ✓ Side Mount
- ✓ Bi-directional options



Bottom Mount



Side Mount

Certification Information

1. Meet RoHS (2011/65/EU)
2. CE certified

Nomenclature

AREV50L B - AN

Series code:
"AREV50L" = AREV50L

Latching Coils:
"B " = 12 VDC
"C " = 24 VDC
"E " = 48 VDC

Latching Coil Wiring Options:
"2 " = 2 Wire, Single Coil

Options:
Blank = Std. Options (Bottom Mount, Without Aux. Contact & Polarized Load Terminals)
"A" = With Aux. Contact (SPST-NO)
"N" = Non-Polar Load Terminals
"S" = Side Mount

Product Data Sheet

MAIN CONTACT

Contact Arrangement	(SPST-NO)
Load connection	M5 screw thread female
Rated Load Voltage	12-900VDC
Break Current at 320VDC	500A 1 cycle
Voltage Drop (@50A)	≤30mV
Dielectric Withstanding Voltage	Between Contacts to Coil 2,200 Vrms @ sea level (leakage <1mA)
Insulation Resistance @ 500VDC (megohms)	100;50 at end of life
Mechanical Life	200,000 cycles

LOAD LIFE (Resistor Load)

50A/450VDC	10,000 cycles
25A/450VDC	50,000 cycles
100A/-450VDC	1,000 cycles
150A/-450VDC	500 cycles

AUX CONTACT

Aux. Contact Arrangement	1 Form A
Aux. Contact Resistance	0.5ohms@30VDC
Aux. Contact Max. current	0.5A@28VDC

SHORT TIME OVERLOAD CURRENT 10mm²

50A @85°C	Continuous
75A @40°C	15 min
100A @40°C	3 min
150A @40°C	30 sec

OPERATE TIME @ 25°C

Close (includes bounce)	25ms, Max.
Bounce (after close only)	5ms, Max.
Release (includes arcing)	10ms, Max.

LATCHING SINGLE COIL (2 WIRE)

Coil Code	B2	C2	E2
Rated Voltage*	12VDC	24VDC	48VDC
Max Operate Voltage	16VDC	28VDC	52VDC
Must Set and Reset Voltage (20°C) Max.	9VDC	18VDC	36VDC
Coil Current (20°C@Rated Voltage)	0.461A	0.25A	0.122A
Max Pick-Up Voltage (85°C)	9.6VDC	19.2VDC	38.4VDC
Coil Resistance ± 10% (20°C)	26Ω	96Ω	392Ω

ENVIRONMENTAL DATA

Shock	Functional	196m/s ² Sine half-wave pulse
	Destructive	490m/s ² Sine half-wave pulse
Operating Temperature	-55°C to +85°C	
Altitude	<4000m	
Weight	190g	

Estimated Make & Break Power Switching Ratings

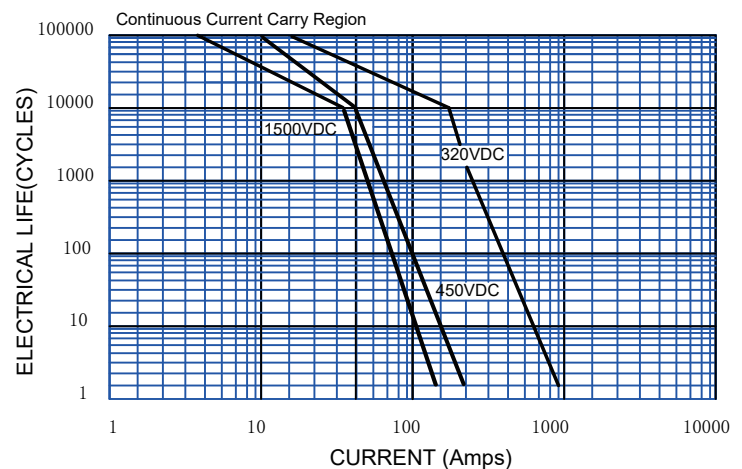

Outline Dimensions (mm):

- Bottom Mount

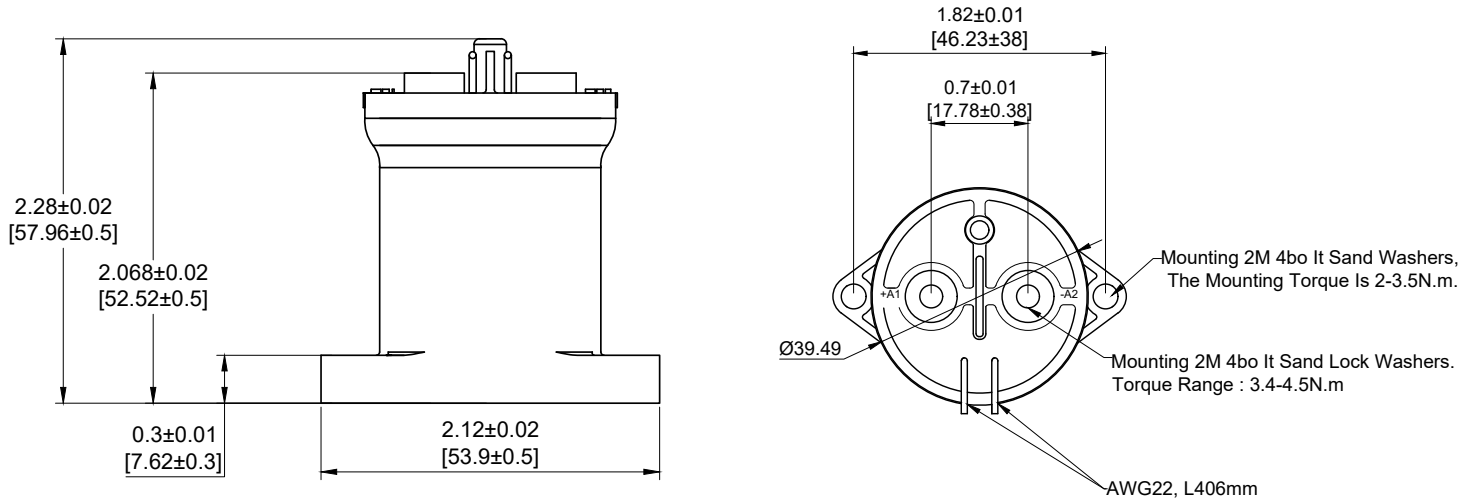

- Sid Mount

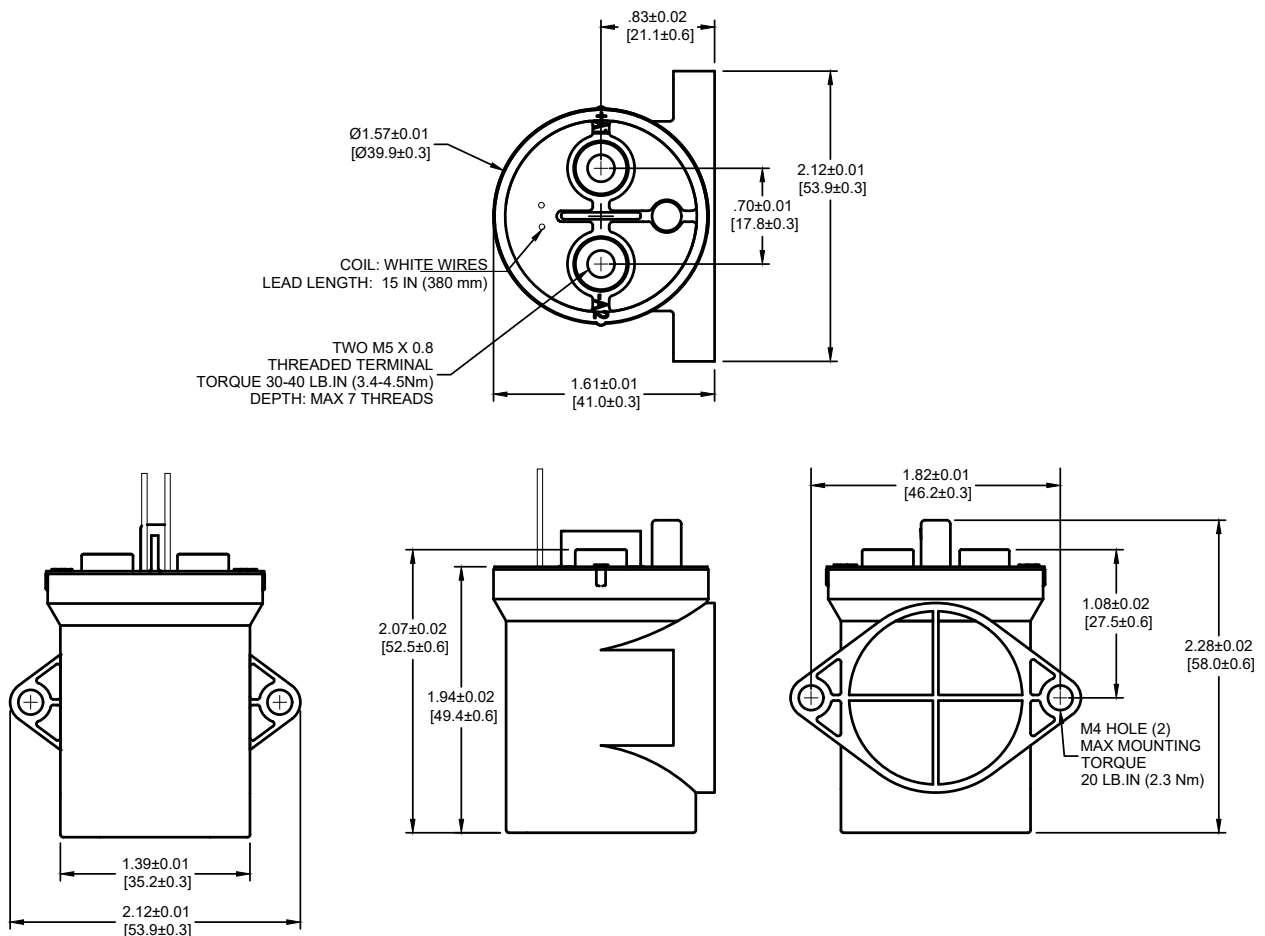

Application Notes

1. To prevent loosening, split washers should be used whenever the contactor is installed. All terminals or copper conductors must be in direct contact with the contactor's main terminals. Please control the tightening torque of each part within the specified range in the table below. If the torque exceeds the recommended range, it may cause damage to the sealed cavity and thread damage.
2. Products with polarity marked on the load end must be used correctly according to the product label. When the load connection polarity is reversed, the electrical characteristics promised in this manual cannot be guaranteed.
3. Products with a coil economizer are already equipped with back EMF circuits, so there is no need to use surge protectors.
4. Avoid installing the contactor in a strong magnetic field environment (near transformers or magnets) and avoid placing the contactor near objects with heat radiation.
5. When continuous current is applied to the contacts of the relay, and the coil is turned on immediately after the power is cut off. At this time, as the temperature of the coil increases, the resistance of the coil will also increase, which will increase the pull-in voltage of the product, which may result in exceeding the rated pull-in voltage. In this case, the following measures should be taken to reduce the load current; limit the continuous power-on time or use a coil voltage higher than the rated pull-in voltage.
6. When the voltage applied to the coil exceeds the maximum allowable applied voltage, the coil temperature may rise and lead to coil damage and inter-layer short circuit.
7. The rated values in the contact parameters are values for resistive load. When using an inductive load with $L/R > 1\text{ms}$, please connect a surge current protection device to the inductive load in parallel. If no measures are taken, the electrical life may be reduced, and the continuity may be poor. Please consider sufficient margin space in the design.
8. Coil drive power must be greater than coil power or it will reduce performance capability.
9. Please do not allow debris and oil to adhere to the main terminals; make sure that the main terminals are in reliable contact with the load conductor, otherwise the temperature rise of the terminal / conductor connection may be too high due to the excessive contact resistance.
10. The load conductor must have the corresponding current load capacity and heat dissipation capacity (it is recommended to use a copper bar with a min 100mm^2), to prevent overheating and affecting the life of the contactor.
11. It is impossible to determine all the performance parameters of contactors in each specific application, therefore, customers should choose the products matching them according to their own conditions of use. If in doubt, contact Altran. The customer will be responsible for validating that the products meet their application.
12. Do not use if dropped.
13. Altran reserves the right to make changes as needed. Customers should reconfirm the contents of the specification or ask for us to supply a new specification if necessary.