

Features

HIGH CURRENT CARRY AND HIGH VOLTAGE

Inert gas filled arc chamber suitable for high voltage switching

COMPACT STRUCTURE, LOW NOISE

Small, low-profile design with low noise while carrying or switching loads

SAFE FOR EXPLOSIVE ENVIRONMENTS

No arc leakage due to a hermetically sealed design

HIGH RELIABILITY DESIGN

Hermetic sealing creates a stable environment for high voltage switching

NO SPECIFIC MOUNTING ARRANGEMENT

Mountable in any orientation without reduction of performance

VARIOUS APPLICATIONS

Battery disconnect, EV charging, energy storage systems, photovoltaics, power control, circuit protection and much more

Sealing Type: Ceramic

- ✓ Non-polar



Certification Information

1. Meet RoHS (2011/65/EU)
2. CE Certified

Nomenclature

AEVF250

B

-

Series code:

“AEVF250” = AEVF250

Coil Voltage Code:

“B” = 12VDC

“C” = 24VDC

Options:

Blank = Std. Options (Bottom Mount, Without Aux. Contact & Non-Polarized Load Terminals)

“S” = Side Mount Version

MAIN CONTACT

Contact Arrangement	1 Form A (SPST-NO)	
Rated Operating Voltage	1000VDC	
Rated Current	250A (60mm ²)	
Short Term Current (85 °C)	500A (120s)	
Contact Resistance	≤0.3mV@250A	
Dielectric Withstanding Voltage (initial)	Between Open Contacts	3000VAC 1mA 1min
	Between Contacts to Coil	3000VAC 1mA 1min
Insulation Resistance (initial)	Terminal to Terminal	New: Min 1000MΩ@1000VDC
	Terminals to Coil	
Limit breaking	1200A@1000VDC, 1 Cycle 2000A@450VDC, 1 Cycle	
Form of the load outlet	M6 Internal thread	

OPERATE / RELEASE TIME

Operate Time	30ms, Max. @23°C
Release Time	10ms, Max. @23°C

ENVIRONMENTAL DATA

Shock	Functional	147m/s ² Sine half-wave pulse
	Destructive	490m/s ² Sine half-wave pulse
Operating Temperature	-40 to +85 °C	
Humidity	5% to 95%RH	
Weight	0.837Lb (380g)	

COIL DATA

Nominal Voltage	12VDC	24VDC
Pick-up Voltage (-40 to +85°C)	≤9VDC	≤18VDC
Drop-out Voltage (-40 to +85°C)	≥1VDC	≥2VDC
Coil Power (23°C)	6W	6W
Rated Coil Resistance ±10%	24 Ω	96 Ω

Current Tolerance and Short Circuit Curves

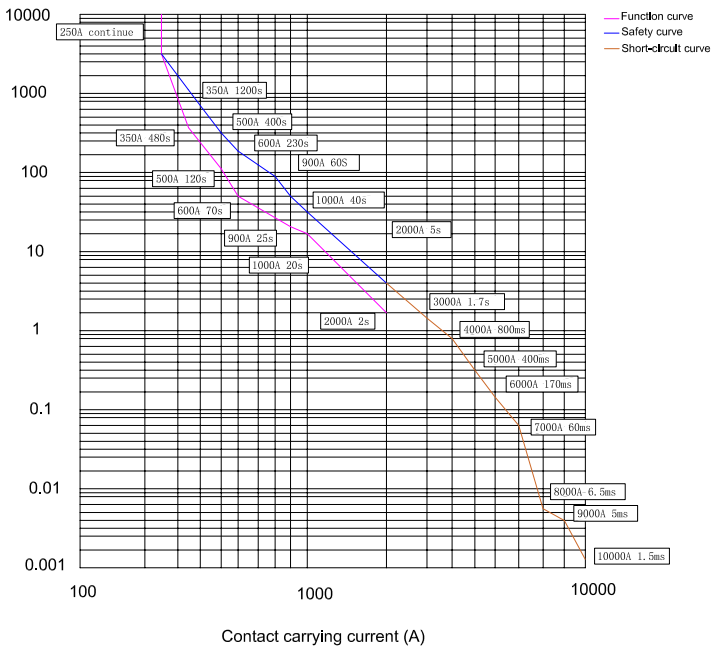

Note:

1. The upper limit of safe temperature rise set by the curve is 180°C, and the upper limit of functional temperature rise is 130°C;
2. When the product is working for a long time, the recommended temperature limit is not more than 130°C;
3. The ambient temperature of the curve is 85°C, and the cross-sectional area of the wire is ≥60mm²;
4. The brown curve indicates that the relay short circuit does not actually ignite or explode.

EXPECTED LIFE

Electrical Endurance (Break only) 250A@450VDC	1000 Cycles
Electrical Endurance (Break Only) 400A@450VDC	300 Cycles
Mechanical Life	200,000 Cycles

Outline Dimensions (mm):

Bottom Mount

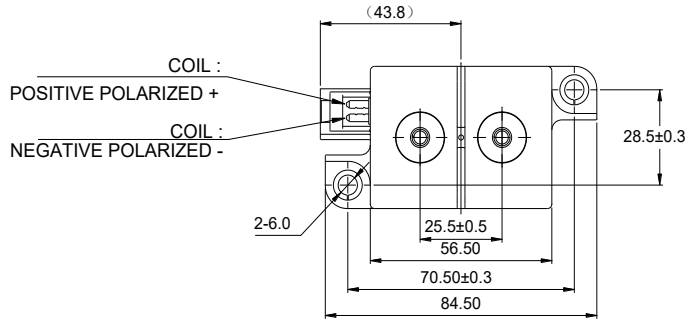

TOLERANCES UNLESS OTHERWISE SPECIFIED	
0~10	±0.3
10~50	±0.6
50~	±1.0

Inner Thread

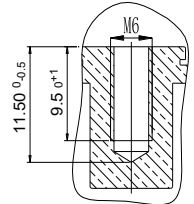

MALE CONNECTOR P/N: 7282-1020(YAZAKI)
 FEMALE CONNECTOR P/N: 7283-1020(YAZAKI)
 (REFERENCE)

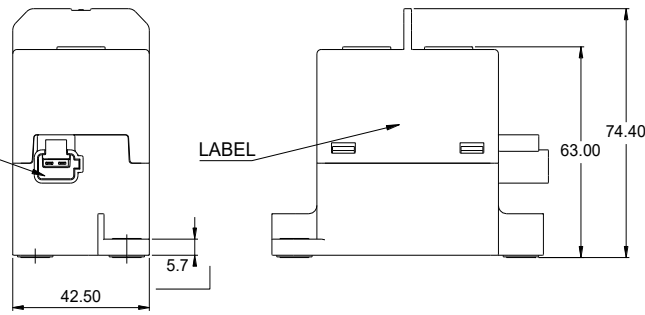

Side Mount

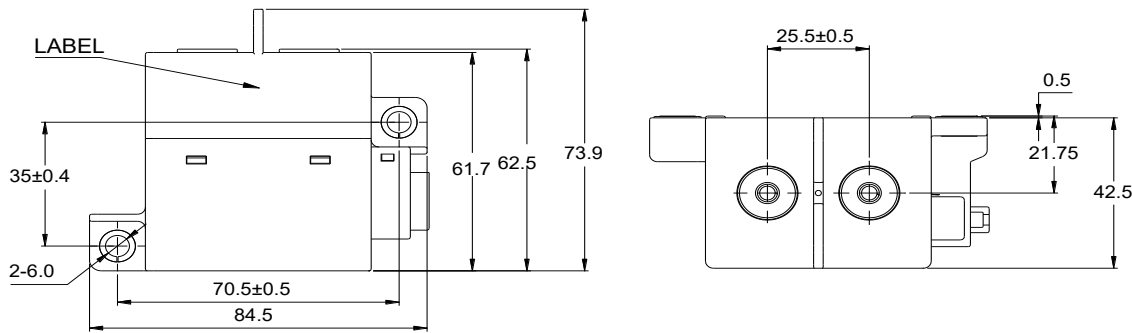

TOLERANCES UNLESS OTHERWISE SPECIFIED	
0~10	±0.3
10~50	±0.6
50~	±1.0

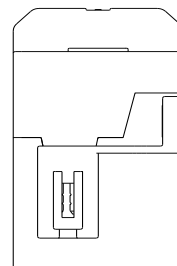
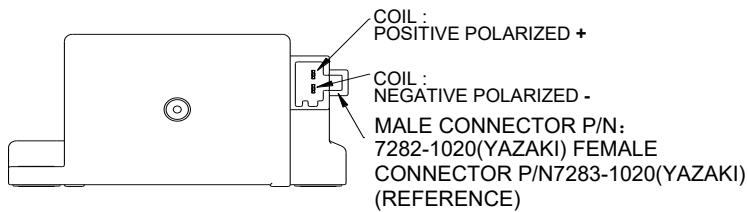
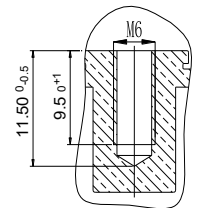

*Note: The wire size is 22AWG, diameter 2.8mm including insulation layer

Application Notes

1. Be sure to use split washers to prevent nuts from loosening. All the terminals or conductors must be in direct contact with the contactor's terminals.
 - Contact Terminal Torque: 53 - 70 lb.in (6 - 8 N.m)
 - Mounting Torque: 27 - 35 lb.in (3 - 4 N.m)
2. This is a product without a circuit board. When the coil turns off, the reverse electromotive force will appear. It is recommended to design a surge protection circuit to absorb the reverse electromotive force of the relay coil.
3. Do not use if dropped.
4. Avoid installing in a strong magnetic field (close to a transformer or magnet) or near a heat source.
5. The coil and contact of the relay are continuously energized, and the power supply is cut off and immediately connected. At this time, the resistance of the coil will increase due to the increase of the temperature of the coil, so the suction voltage of the product will increase, which may lead to the excess of the rated suction voltage. In this case, the following measures should be taken: reduce the load current, Limit continuous power, or use coil voltage higher than the rated suction voltage.
6. When the voltage applied to both ends of the coil exceeds the maximum allowable applied voltage, the coil temperature may rise and lead to coil damage and inter-layer short circuit.
7. The rating in the contact parameters is the value at the time of the resistive load. When using an inductive load with $L/R > 1\text{ms}$, connect a surge current protection device in parallel with the inductive load. If no measures are taken, the electrical life may be degraded, and the continuity may be poor. Please consider sufficient margin space in the design.
8. Drive power must be greater than coil power, or it will reduce performance capability.
9. Please do not allow debris and oil to adhere to the main lead end. Make sure that the external terminals are in reliable contact with the main outgoing end of the product; otherwise, the temperature rise of the outgoing end may be too high due to the excessive contact resistance.
10. The lead wire connected with the high voltage end of the product must have the corresponding current load capacity and heat dissipation capacity to prevent overheating from affecting the life of the contactor.
11. It can be impossible for Altran Magnetics to determine all the performance parameters of relays in each specific application area; therefore, customers should choose the products matching them according to their conditions of use. If in doubt, contact Altran. However, the customer is responsible for what they choose. It is the user's responsibility to determine.
12. Altran Magnetics reserves the right to make changes. Customers should reconfirm the contents of the specification before first orders and ask us to supply a new specification if necessary.