

Features

COMPACT STRUCTURE, LOW NOISE

Small, low-profile designs with low noise while carrying or switching loads

HIGH RELIABILITY DESIGN

Hermetic sealing creates a stable environment for contact resistance

NO SPECIFIC MOUNTING ARRANGEMENT

Mountable in any orientation without reduction of performance

VARIOUS APPLICATIONS

Battery Disconnect, EV and Charging, Energy Storage Systems, Photo Voltaic, Power Control, Circuit protection and much more

PRE-CHARGE CONTACTOR

Specific Attributes

-Quick connect tabs or PCB mount

Sealing Type: Epoxy



Certification Information

1. UL Approved
2. Meet RoHS (2011/65/EU)
3. CE certified

Nomenclature

AEV20E

B

-

Series code:

“AEV20E” = AEV20E

Coil Voltage Code:

“B” = 12VDC

“C” = 24VDC

Blank = Std.Options (Bottom Mount, Quick Connect Terminals)

“P” = PCB Terminals (no mounting tabs)

Product Data Sheet

MAIN CONTACT

Contact Arrangement	1 Form X (SPST-NO)	
Rated Operating Voltage	820 VDC	
Rated current	20A (4mm ²)	
Short Term Current	30A (1h)	
Dielectric Withstanding Voltage (initial)	Between Open Contacts	2500 1mA 1min
	Between Contacts to Coil	3000VAC 1mA 1min
Insulation Resistance (Initial)	Terminal to Terminal	Min. 1000 M Ω @500 VDC
	Terminals to Coil	
Contact Voltage Drop (initial)	\leq 50mV/10A	
Limit Breaking	30A@450VDC, 5 Cycle	

OPERATE / RELEASE TIME

Operate Time	\leq 30ms @20°C
Release Time	\leq 10ms @20°C

ENVIRONMENTAL DATA

Shock	Functional	196m/s ² (20g) Sine half-wave pulse
	Destructive	490m/s ² (50g) Sine half-wave pulse
Operating Temperature	-40 to +85°C	
Humidity	5% to 85%RH	
Weight	0.11Lb (50g)	

EXPECTED LIFE

Electrical Endurance (Make/Break) 20A@450VDC	5,000 Cycles
Electrical Endurance (Make/Break) 10A@450VDC	10,000 Cycles
Electrical Endurance (Make Only) 20A@450VDC	75,000 Cycles
Mechanical Life	200,000 Cycles

COIL DATA

Nominal Voltage	12VDC	24VDC
Pick-up Voltage (23°C)	\leq 9VDC	\leq 18VDC
Drop-out Voltage (23°C)	\geq 0.8 VDC	\geq 1.6 VDC
Coil Power 20°C at Nominal Voltage	3W	3W
Rated Coil Resistance \pm 10% (23°C)	48 Ω	192 Ω

Current Carry Curve

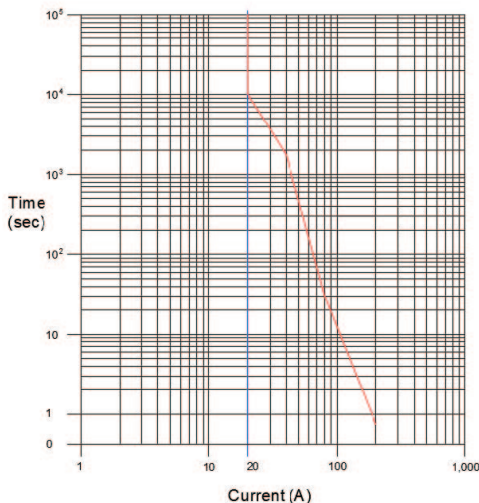

Note:

1. Do not meet dielectric & IR after the test.
2. ON:OFF= 1s:9s.
3. The ambient environment of application should not cause any dewing or icing inside the relay. Otherwise, the relay may fail to work consequently.

Outline Dimensions : inches (mm)

AEV20E

AEV20E(P)

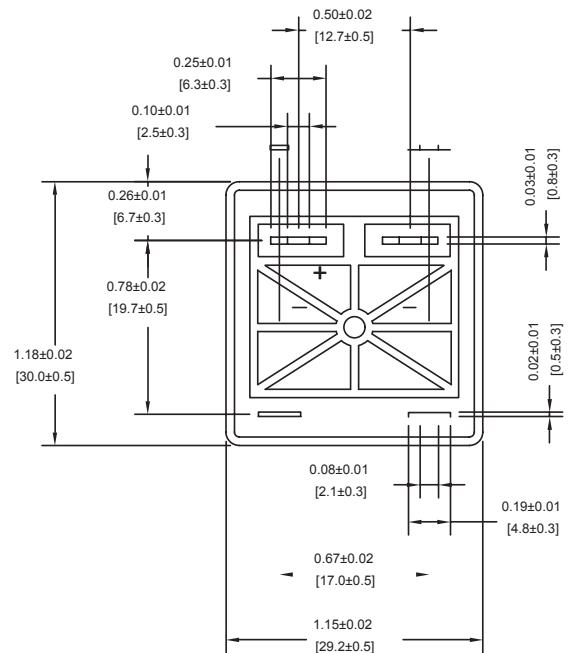
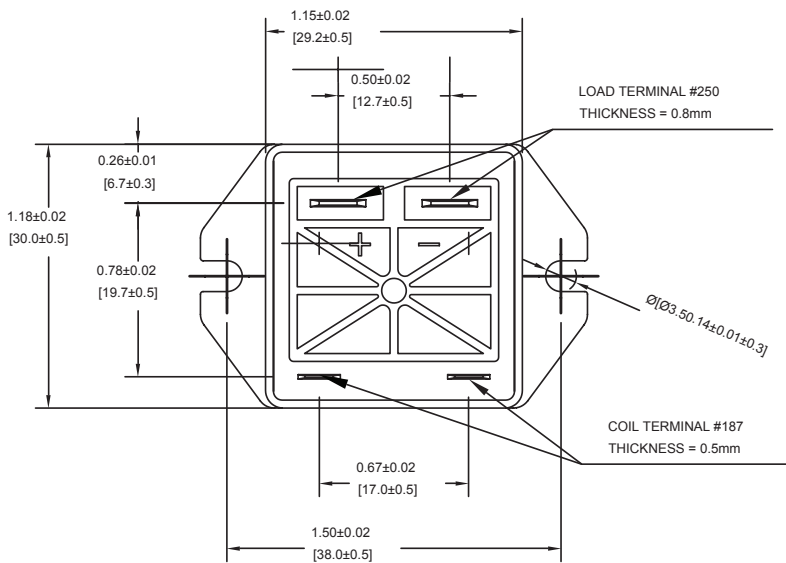
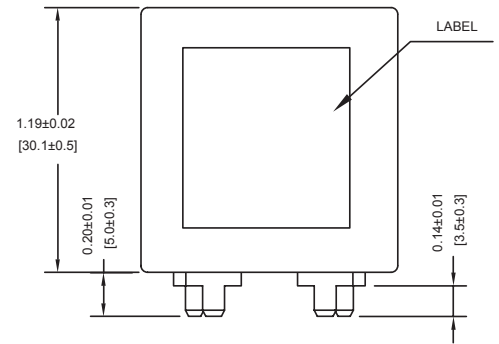
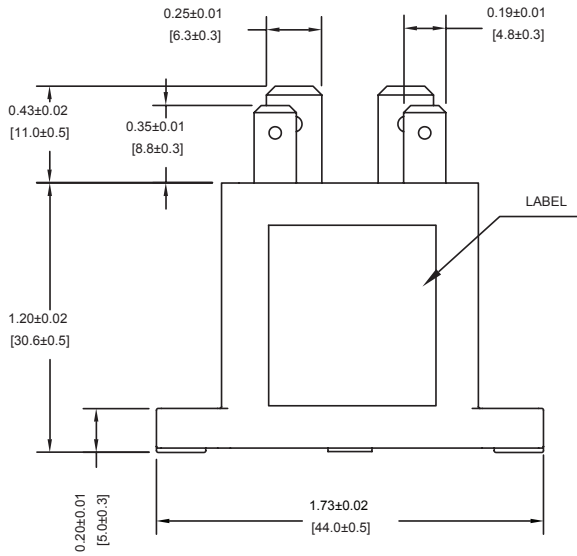

NOTE: There is a "+" and "-" mark on the cover of the product to show the polarity of the load, the coil has no polarity.

Application Notes

1. Please use M3 screws for mounting.
 - Mounting torque: 0.8~1.1N. m.
2. Maximum allowable (push-on) force of the terminals is 49N.
3. PCB soldering parameters:
 - Manual soldering, 380±20°C, time (3~5)s.
 - Wave soldering 265±5°C, time (3~8)s.
4. Products with polarity marked on the load end must be used correctly according to the product marking. When the load connection polarity is reversed, the electrical characteristics promised in this manual cannot be guaranteed.
5. Avoid installing the contactor in a strong magnetic field environment (near transformers or magnets) and placing it near objects with heat radiation.
6. When continuous current is applied to the relay contacts, the Coil is turned on immediately after the power is cut off. At this time, as the Coil's temperature increases, the Coil's resistance will increase, which will increase the pull-in voltage of the product, which may result in exceeding the rated Pull-in voltage. In this case, the following measures should be taken to reduce the load current: limit the continuous power-on time or use a coil voltage higher than the rated pull-in voltage.
7. When the voltage applied to both ends of the Coil exceeds the maximum allowable applied voltage, the coil temperature may rise, leading to coil damage and an inter-layer short circuit.
8. The rating in the contact parameters is the value at the time of the resistive load. When using an inductive load with $L/R > 1\text{ms}$, connect a surge current protection device in parallel with the inductive load. If measures are taken, the electrical life may be maintained, and the continuity may be suitable. Please consider sufficient margin space in the design.
9. Supply power must be greater than coil power, or it will reduce performance capability.
10. The load conductor must have the corresponding current load capacity and heat dissipation capacity (it is recommended to use wire with a minimum of 4mm²) to prevent overheating and affect the life of the contactor.
11. Do not use if dropped.
12. It is impossible to determine all the performance parameters of contactors in each specific application. Therefore, customers should choose the products matching them according to their own conditions of use. If in doubt, contact Altran; however, the customer will be responsible for validating that the products meet their application.
13. Altran reserves the right to make changes as needed. Customers should reconfirm the specification's contents or ask us to supply a new specification if necessary.