

Features

HIGH CURRENT CARRY AND HIGH VOLTAGE

Inert gas filled arc chamber suitable for high voltage switching

COMPACT STRUCTURE, LOW NOISE

Small, low-profile design with low noise while carrying or switching loads

COIL ECONOMIZER

Economized coil for low power consumption

SAFE FOR EXPLOSIVE ENVIRONMENTS

No arc leakage due to a hermetically sealed design

HIGH RELIABILITY DESIGN

Hermetic sealing creates a stable environment for high voltage switching

VARIOUS APPLICATIONS

Battery disconnect, EV charging, energy storage systems, photovoltaics, power control, circuit protection and much more

Sealing Type: Epoxy/Resin

- ✓ Perfect for energy storage applications
- ✓ Bidirectional switching



Certification Information

1. Meet RoHS (2011/65/EU)
2. CE certified
3. UL approved

Nomenclature

AES500

MAN

Series code:
"AES500" = AES500

Coil Voltage Code:
"MAN" = 12-24VDC coil, with Aux. Contact (SPST-NO) and Non-Polarized Load Terminals

Product Data Sheet

MAIN CONTACT		
Contact Arrangement	1 Form X (SPST-NO)	
Rated Operating Voltage	1500VDC	
Rated Current	600A	
Max Short Circuit Current	2500A (20s)	
Dielectric Withstanding Voltage (initial)	Between Open Contacts	4500 VAC/5mA/60s
	Between Contacts to Coil	4500 VAC/5mA/60s
Insulation Resistance (initial)	Terminal to Terminal	Min. 1000 MΩ@500VDC
	Terminals to Coil	Min. 1000 MΩ@500VDC
Contact Voltage Drop (initial)	Max. 0.5 mΩ (Max. 50mV/100A)	
Short Term Current	1000A (1min.) / 2000A (0.5min)	

EXPECTED LIFE	
Electrical Endurance	500A@750VDC, 1000 Cycles 100A@1500VDC, 6000 Cycles
Mechanical life	200,000 cycles

Current Carry Curve (300m² conductor)

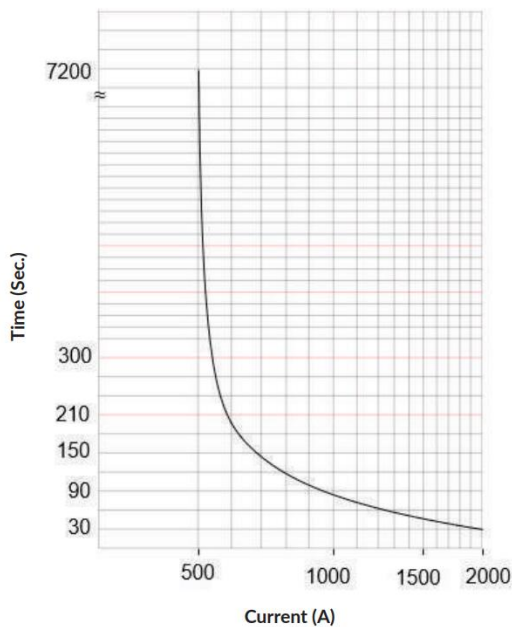

OPERATE / RELEASE TIME	
Operate Time	40ms, Max. @20°C
Release Time	10ms, Max. @20°C

ENVIRONMENTAL DATA		
Shock	Functional	196m/s ² Sine half-wave pulse
	Destructive	490m/s ² Sine half-wave pulse
Operating Temperature	-40 to +85°C	
Humidity	5% to 85%RH	
Weight	2.6 Lb. (1180g)	

COIL DATA	
Nominal Voltage	12/24 VDC
Pick-up Voltage 20°C	8-9VDC
Drop-out Voltage 20°C	5-7VDC
Max. Inrush Current 20°C	3.8A
Average Holding Current 20°C	0.34A@12VDC / 0.16A@24VDC 0.1A@36VDC

AUX. CONTACT	
Aux. Contact Arrangement	1 Form A
Aux. Contact/Current Max.	3A@24VDC / 3A@125VAC
Aux. Contact Current Min.	100mA@8v

Electrical Life

Estimated Make and Break Resistive Load Ratings

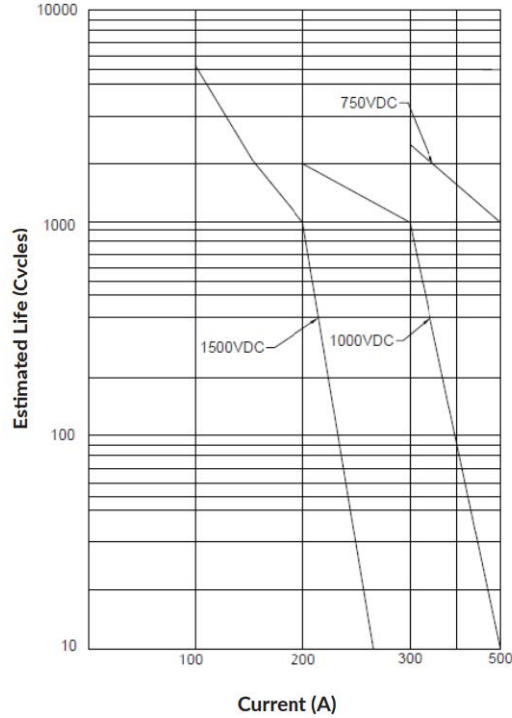

Outline Dimensions : inches (mm)

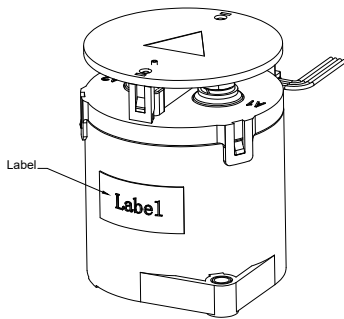

Matching fastener components:
 2 x M8 stainless steel flat washer
 2 x M8 stainless steel spring washer
 2 x M8x1.25 stainless steel nut
 Torque: 8.8-11N.m

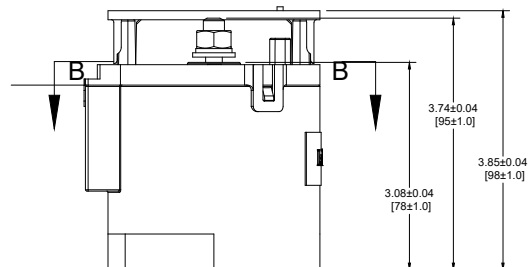
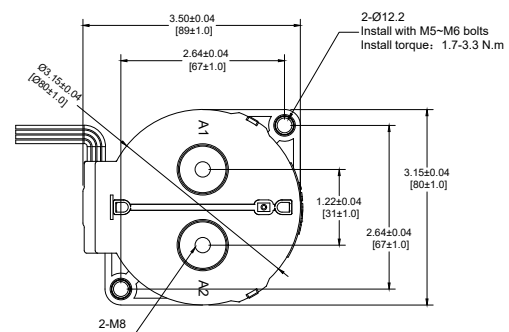
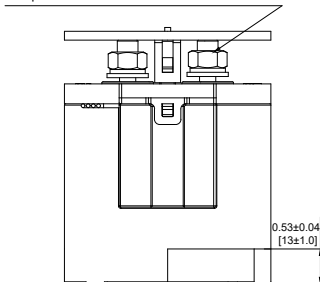

*Note:

1. The wire size is 22 AWG
2. The wire length is 15.4±0.4 (390 ± 10)

Application Notes

1. To prevent loosening, split washers should be used whenever the contactor is installed. All terminals or conductors must be in direct contact with the contactor's main terminals. Please control the tightening torque of each part within the specified range in the table below. If the torque exceeds the recommended range, it may cause damage to the sealed cavity and thread damage.
 - Contact torque: M8: 80-100 lb.in (8.8 - 11 N.m)
 - Mounting torque: 15 - 30 lb.in (1.7 - 3.3 N.m)
2. Products with polarity marked on the load end must be used correctly according to the product label. When the load connection polarity is reversed, the electrical characteristics in this data sheet cannot be guaranteed.
3. Products with a coil economizer are already equipped with back EMF circuits, so there is no need to use surge protectors.
4. Avoid installing the contactor in a strong magnetic field environment (near transformers or magnets) and avoid placing the contactor near objects with heat radiation.
5. When continuous current is applied to the contacts of the relay, and the coil is turned on immediately after the power is cut off. At this time, as the temperature of the coil increases, the resistance of the coil will also increase, which will increase the pull-in voltage of the product, which may result in exceeding the rated pull-in voltage. In this case, the following measures should be taken to reduce the load current; limit the continuous power-on time or use a coil voltage higher than the rated pull-in voltage.
6. When the voltage applied to the coil exceeds the maximum allowable applied voltage, the coil temperature may rise and lead to coil damage and inter-layer short circuit.
7. The rated values in the contact parameters are values for resistive load. When using an inductive load with $L/R > 1\text{ms}$, please connect a surge current protection device to the inductive load in parallel. If no measures are taken, the electrical life may be reduced and the continuity may be poor. Please consider sufficient margin space in the design.
8. Coil drive power must be greater than coil power or it will reduce performance capability.
9. Please do not allow debris and oil to adhere to the main terminals; Make sure that the main terminals are in reliable contact with the load conductor, otherwise the temperature rise of the terminal / conductor connection may be too high due to the excessive contact resistance.
10. The load conductor must have the corresponding current load capacity and heat dissipation capacity (it is recommended to use a copper bar with min 300mm^2), to prevent overheating and affecting the life of the contactor.
11. It is impossible to determine the performance parameters of contactors in each specific application, therefore, customers should choose the products according to their own conditions of use. If in doubt, contact Altran. The customer will be responsible for validating that the products meet their application.
12. Do not use if dropped.
13. Altran reserves the right to make product changes as needed. Customers should reconfirm the contents of the specification or ask for us to supply a new specification if necessary.